



光电耦合器

OPTOCOUPLER

产品规格书
Product Data Sheet

Si-314 系列

Si-314 Series

Si DCC
Release

贵州硅耐光电有限公司

GuiZhou Silicon Nice Optoelectronic Co., Ltd.

描述 Description

Si-314 系列有一个发光二极管，通过红外光与光敏集成电路耦合并合封在宽型六脚贴片封装中。该系列光耦非常适合驱动电机控制逆变器应用中的 IGBT 和功率 MOSFET。

The Si-314 series has a infrared emitting diode, which is optically coupled to an integrated photodetector IC chip, and is incorporated in a Stretched SO-6 package. These optocouplers are ideally suited for driving IGBTs and power MOSFETs used in motor control inverter applications.

典型应用 Typical Applications

- 工业逆变器
Industrial inverters
- IGBT 和功率 MOSFET 栅极驱动
IGBT and Power MOSFET Gate Drivers
- 交流和直流无刷电机驱动
AC and Brushless DC motor drives
- 功率开关电源
Switching Power Supplies (SPSs)

真值表 Truth Table			
LED	$V_{CC}-V_{SS}$ (Turn-ON, +ve going)	$V_{CC}-V_{SS}$ (Turn-OFF, -ve going)	VO
OFF	0V to 30V	0V to 30V	Low
ON	0V to 6.9V	0V to 5.9V	Low
ON	6.9V to 8.7V	5.9V to 7.5V	Transition
ON	8.7V to 30V	7.5V to 30V	High

特性 Features

- 输出峰值电流最大±1A，最小±1A
Output peak current: ±1 A (max), ±1A(min)
- 宽工作电压范围：10~30V
Wide V_{CC} operating range: 10V to 30V
- 输入-输出隔离电压最小 5000 V_{RMS}
Input-output Isolation Voltage 5000 V_{RMS} (min)
- 宽工作温度：-40~110°C
Wide operating temperature range: -40°C to 110°C

封装与功能图 Package and Functional Diagram

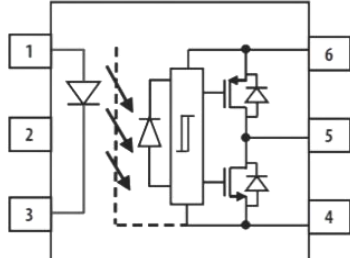
封装 Package	内部连接图 Internal Connection Diagram	引脚分配 Pin Assignment
 LSOP6-P LSOP6-W		1: Anode 6: V_{CC} 2: NC 5: V_O 3: Cathode 4: V_{SS}

安规与绝缘参数 Safety and Insulation Ratings

参数 Parameter	符号 Symbol	数值 Value	单位 Unit
最大额定隔离电压 Maximum Rated Withstanding Isolation Voltage	V_{ISO}	5000	V_{RMS}
最大瞬态隔离电压 Maximum Transient Isolation Voltage	V_{IOTM}	7000	V_{peak}
最大峰值重复隔离电压 Maximum Repetitive Peak Isolation Voltage	V_{IORM}	1500	V_{peak}
爬电距离 Creepage Distance	L	7	mm

极限参数 Absolute Maximum Ratings

参数 Parameter	符号 Symbol	最小值 Min.	极限值 Rating	单位 Unit	
输入端 Input	平均输入电流 Average Input Current	$I_{F(AVG)}$	-	20	mA
	反向电压 Reverse Voltage	V_R	-	5	V
	功耗 Power Dissipation	P_I	-	45	mW
	瞬态峰值输入电流(<1 μs pulse width, 300 pps) Peak Transient Input Current (<1 μs pulse width, 300 pps)	$I_{F(TRAN)}$	-	1	A
	结温 Junction Temperature	T_J	-	125	$^{\circ}C$
输出端 Output	输出高-峰值电流 High Peak Output Current	$I_{OH(PEAK)}$	-	1	A
	输出低-峰值电流 High Peak Output Current	$I_{OL(PEAK)}$	-	1	A
	电源电压 Supply Voltage	$V_{CC-V_{SS}}$	0	35	V
	峰值输出电压 Peak Output Voltage	$V_{O(PEAK)}$	-0.5	V_{CC}	V
	输出功率 Power Dissipation	P_O	-	250	mW
	结温 Junction Temperature	T_J	-	125	$^{\circ}C$
工作温度 Operating Temperature	T_{amb}	-40	+110	$^{\circ}C$	
存储温度 Storage Temperature	T_{stg}	-55	+125	$^{\circ}C$	
焊接温度 Soldering Temperature	T_{sld}	-	260	$^{\circ}C$	

推荐的工作条件 Recommended Operating Conditions

参数 Parameter	符号 Symbol	最小值 Min.	最大值 Max.	单位 Unit
电源电压 Power Supply Voltage	$V_{CC-V_{SS}}$	10	30	V
输入开启电流 Input Current (ON)	$I_{F(ON)}$	5	16	mA
输入关断电压 Input Voltage (OFF)	$V_{F(OFF)}$	-3.0	0.8	V



产品特性参数 Electro-optical Characteristics ($T_{amb}=25^{\circ}C$)

参数 Parameter		测试条件 Test Conditions	符号 Symbol	最小值 Min.	典型值 Typ.	最大值 Max.	单位 Units
输入端 Input	输入端正向电压 Input Forward Voltage	$I_F=10mA$	V_F	-	1.9	2.4	V
	反向电压 Input Reverse Breakdown Voltage	$V_R=5V$	I_R	-	-	10	μA
	低到高阈值电流 Threshold Input Current Low to High	$I_O=0mA, V_O>5V$	I_{FLH}	-	0.6	2	mA
	高到低阈值电压 Threshold Input Voltage High to Low	$I_O=0mA, V_O<5V$	V_{FHL}	0.8	-	-	V
	输入端电容 Input capacitance	$V_F=0, f=1MHz$	C_{IN}	-	60	-	pF
输出端 Output	高电平输出电流 High Level Output Current	$I_F=0mA, V_{CC}=30V, V_O=V_{CC}-4$	I_{OH}	1.0	-	-	A
	低电平输出电流 Low Level Output Current	$I_F=0mA, V_{CC}=30V, V_O=V_{SS}+4$	I_{OL}	1.0	-	-	A
	高电平输出电压 High Level Output Voltage	$I_F=10mA, I_O=-100mA$	V_{OH}	29.4	29.69	-	V
	低电平输出电压 Low Level Output Voltage	$I_F=0mA, I_O=100mA$	V_{OL}	-	0.17	0.4	V
	高电平电源电流 High Level Power Supply Current	$I_F=10mA, V_{CC}=30V, V_O=Open$	I_{CCH}	-	1.55	3	mA
	低电平电源电流 Low Level Power Supply Current	$I_F=0mA, V_{CC}=30V, V_O=Open$	I_{CCL}	-	1.92	3	mA
传输特性 Transfer Characteristics	输出高电平传输延迟 Propagation Delay Time to High Output Level	$I_F=10mA, V_{CC}=30V, R_g=47\Omega, C_g=3nF, f=10kHz, Duty\ Cycle=50\%$	t_{PLH}	-	70	110	ns
	输出低电平传输延迟 Propagation Delay Time to Low Output Level		t_{PHL}	-	55	110	ns
	传输延迟差 Propagation Delay Difference Between Any Two Parts or Channels		P_{DD}	-0.1	-	0.1	μs
	上升时间 Rise Time		t_R	-	10	-	ns
	下降时间 Fall Time		t_F	-	10	-	ns
	输出高电平共模抑制 Output High Level Common Mode Transient Immunity	$I_F=7\sim 16mA, V_{CC}=30V, T_A=25^{\circ}C, V_{CM}=1000V$	$ CM_H $	20	40	-	kv/ μs
	输出低电平共模抑制 Output Low Level Common Mode Transient Immunity	$I_F=0mA, V_{CC}=30V, T_A=25^{\circ}C, V_{CM}=1000V$	$ CM_L $	20	40	-	kv/ μs
	低电压锁定阈值 Under Voltage Lockout Threshold	$V_O>5V, I_F=10mA$	V_{UVLO+}	6.9	7.8	8.7	V
	$V_O<5V, I_F=10mA$	V_{UVLO-}	5.9	6.9	7.5	V	
隔离电阻 Isolation Resistance		$V_{I-O}=500V$	R_{ISO}	-	10^{12}	-	Ω
隔离电容 Isolation capacitance		$f=1MHz$	C_{ISO}	-	0.6	-	pF

典型特性曲线 Typical Characteristics Curves

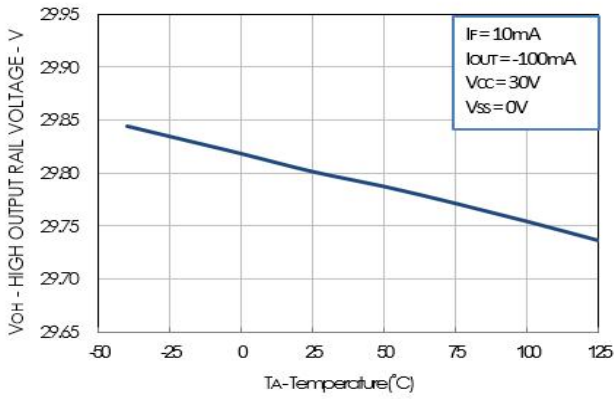

图例 1-高电平输出电压与环境温度曲线图

Fig.1 High output rail voltage vs. Temperature

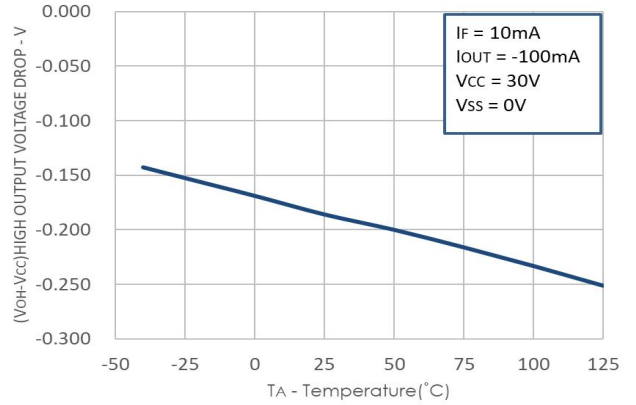

图例 2-输出高电平电压至电源电压与环境温度曲线图

Fig. 2 $V_{OH}-V_{CC}$ vs. Temperature

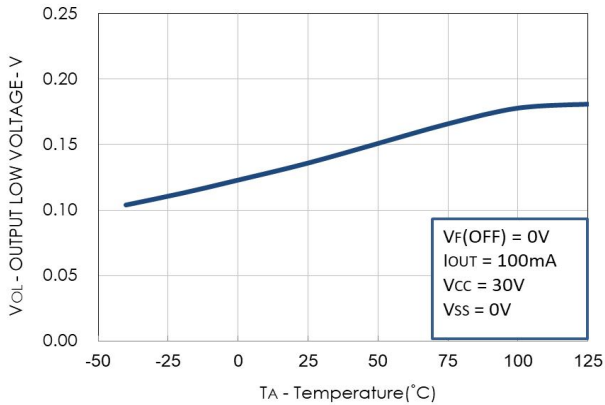

图例 3-低电平输出电压与环境温度曲线图

Fig. 3 - VOL vs. Temperature

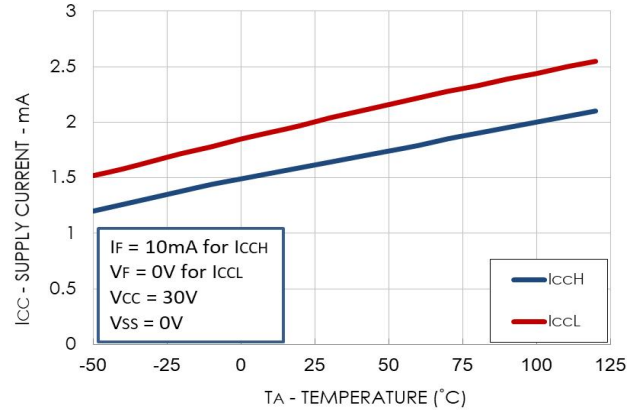

图例 4-电源电流与工作温度曲线图

Fig. 4 ICC vs. Temperature

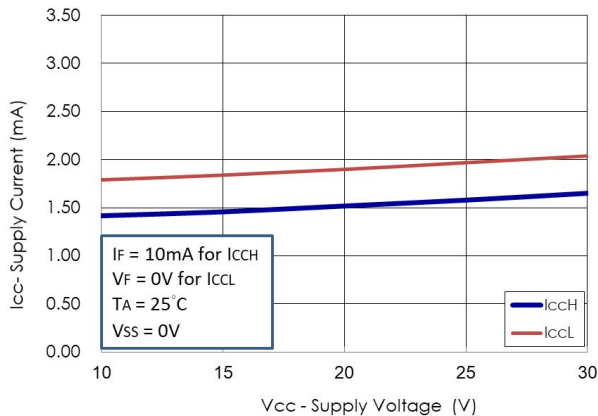

图例 5-电源电流与电源电压曲线图

Fig.5 I_{CC} vs. V_{CC}

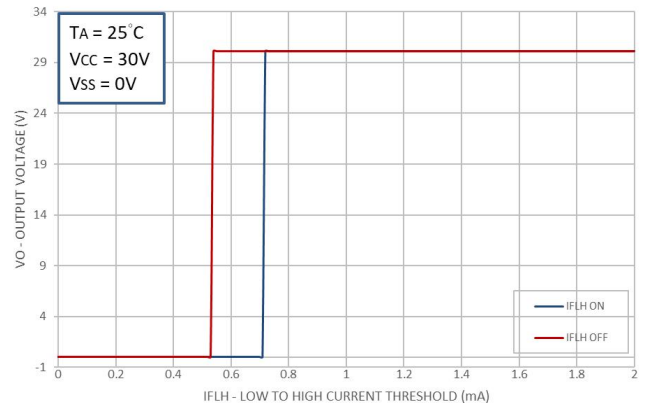

图例 6-输出电压与阈值电流从低到高曲线图

Fig.6 V_O vs. I_{FLH}

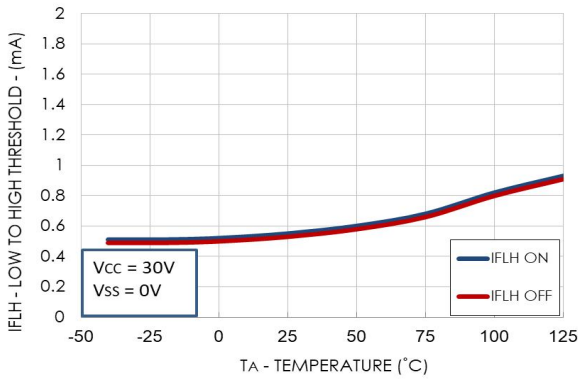

图例 7-阈值电流从低到高与工作温度曲线图
Fig.7 IFLH vs. Temperature

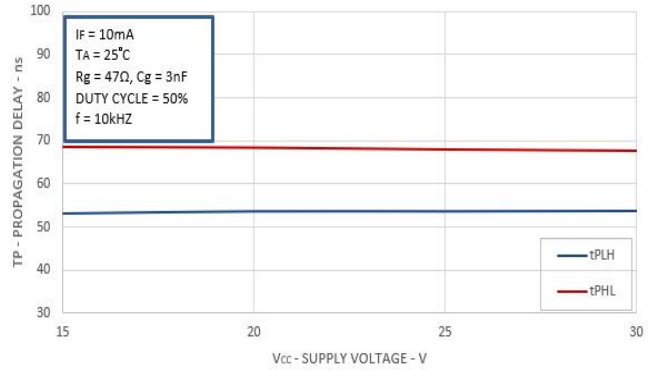

图例 8-传输延时与电源电压曲线图
Fig.8 Propagation Delays vs. VCC

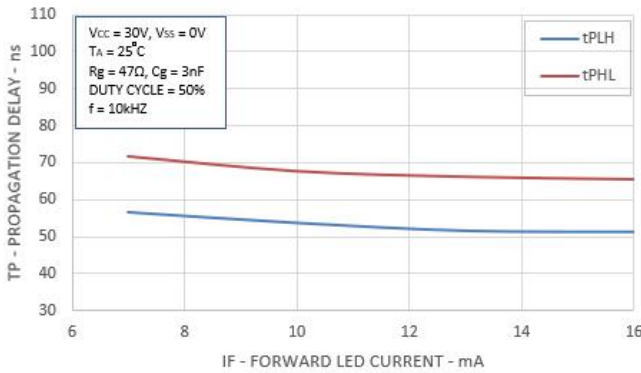

图例 9-传输延时与正向电流曲线图
Fig.9 Propagation Delays vs. IF

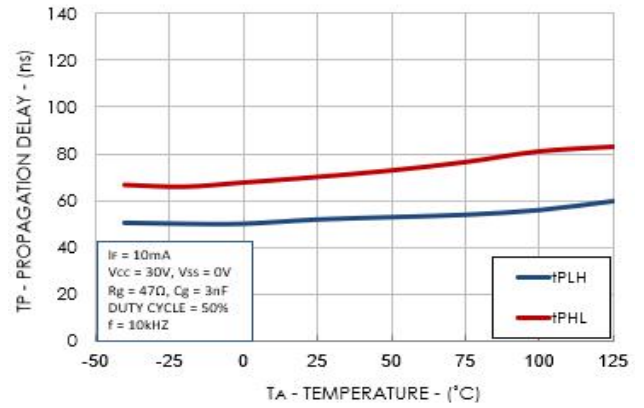

图例 10-传输延时与工作温度曲线图
Fig.10 Propagation Delays vs. Temperature

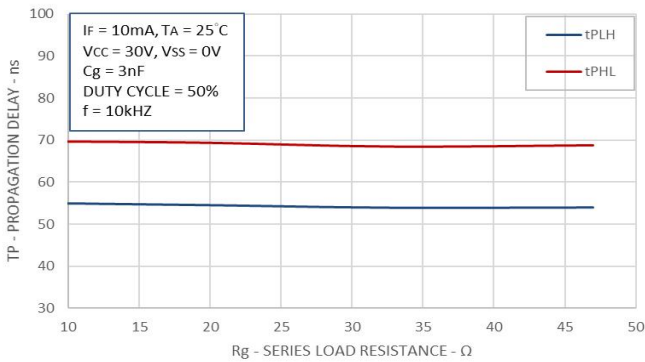

图例 11-传输延时与负载电阻曲线图
Fig.11 Propagation Delays vs. Rg

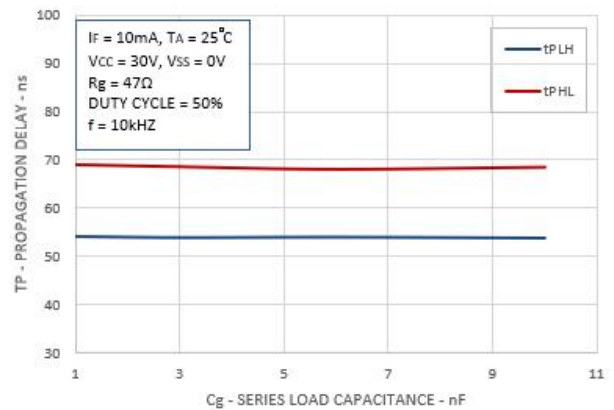

图例 12-传输延时与电容曲线图
Fig.12 Propagation Delays vs. Cg

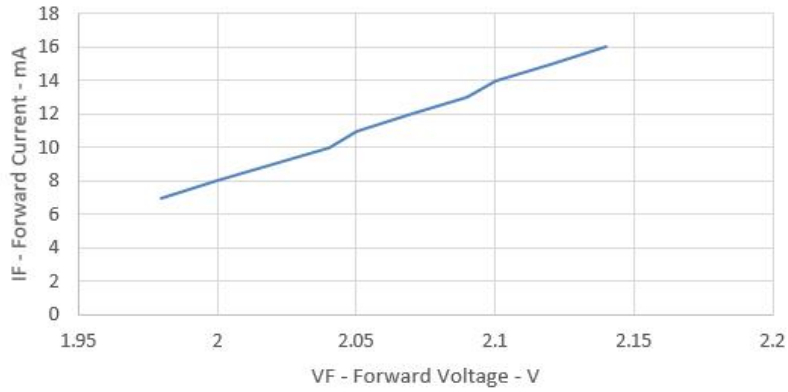

图例 13-正向电流与正向电压曲线图

Fig.13 Input Current vs. Forward Voltage

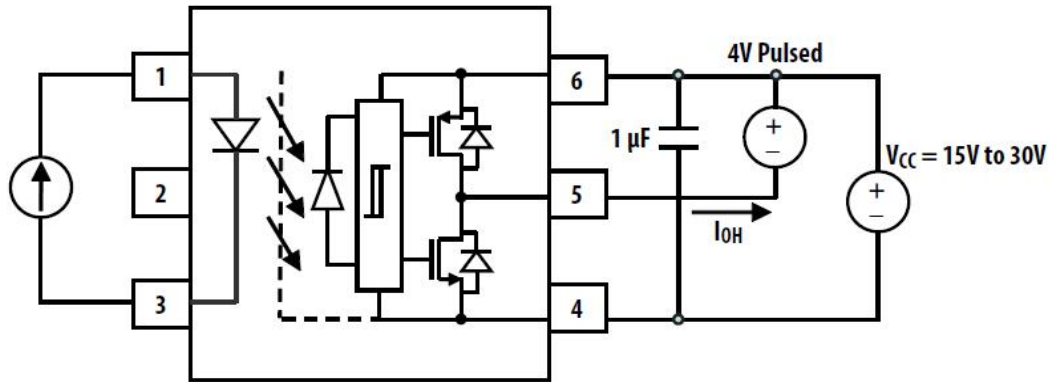

图例 14-IOH 测试电路

Fig.14 IOH Test Circuit

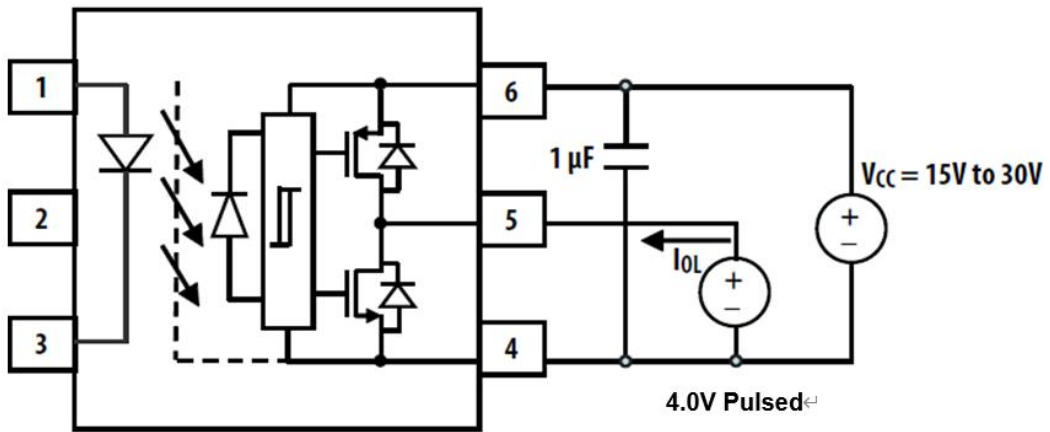

图例 15-IOL 测试电路

Fig.15 IOL Test Circuit

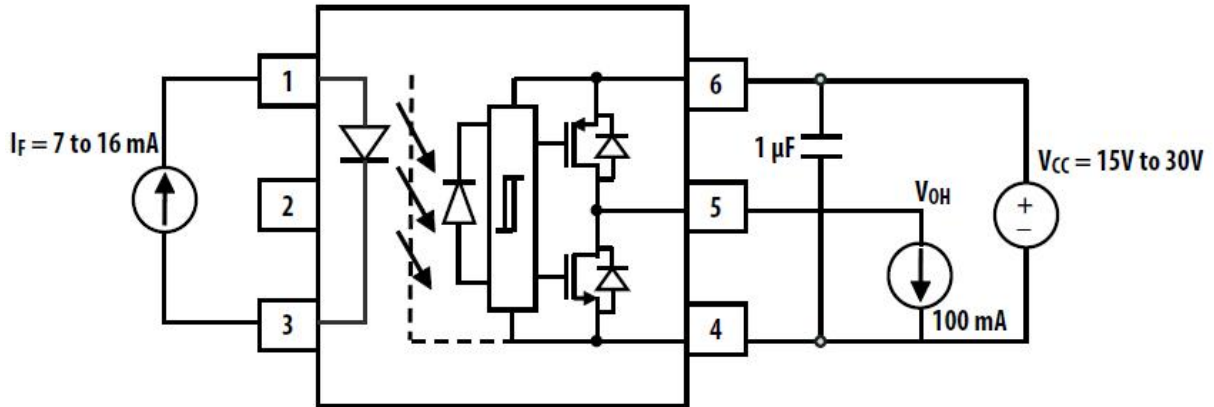

图例 16-VOH 测试电路

Fig.16 VOH Test Circuit

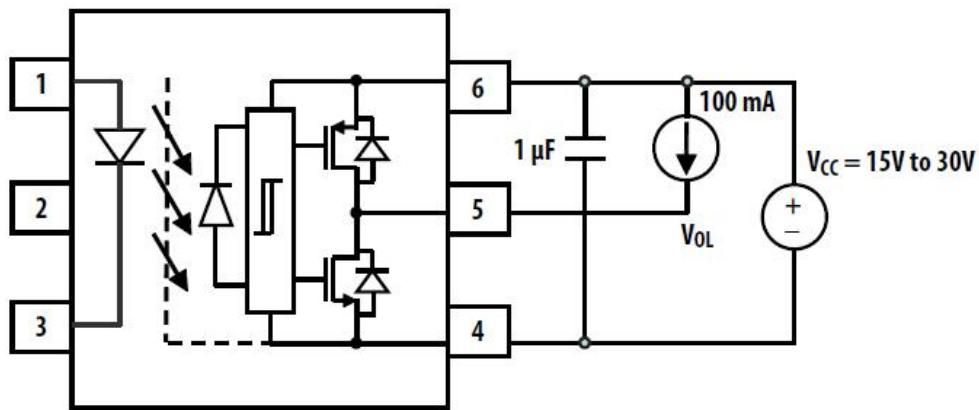

图例 17-VOL 测试电路

Fig.17 VOL Test Circuit

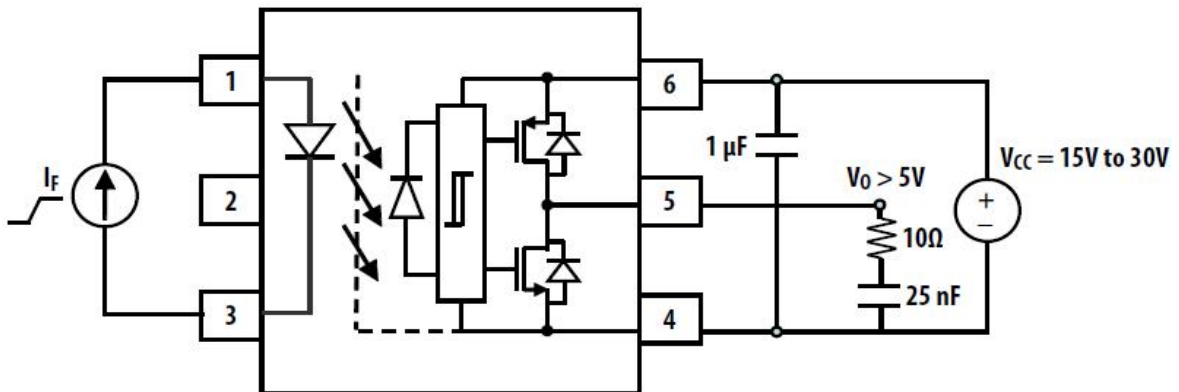

图例 18-IFLH 测试电路

Fig.18 IFLH Test Circuit

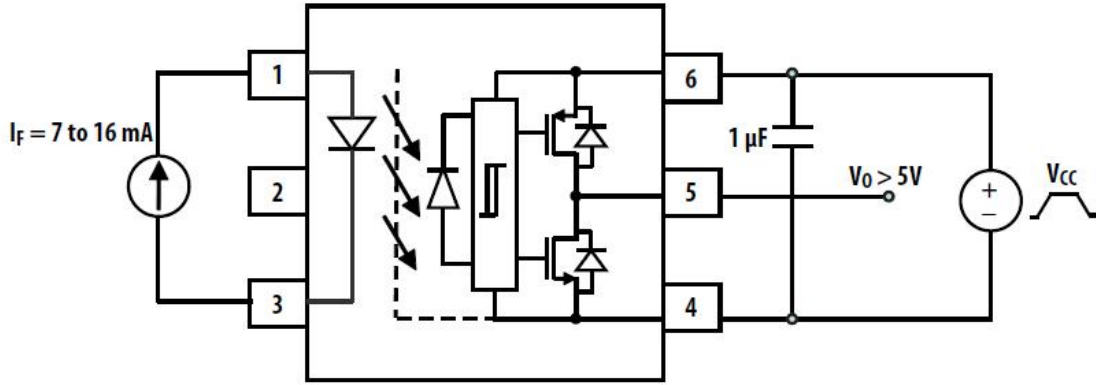

图例 19-UVLO 测试电路
 Fig.19 UVLO Test Circuit

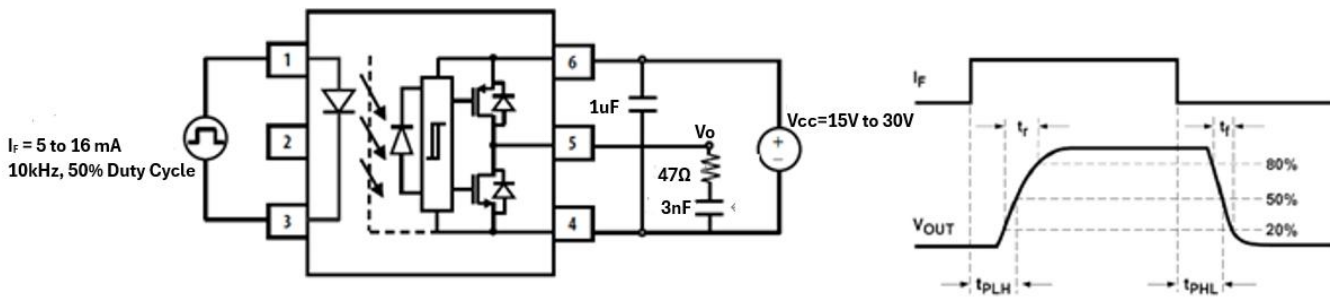

图例 20-传输延时测试电路及波形图
 Fig.20 tPHL, tPLH, tr and tf Test Circuit and Waveforms

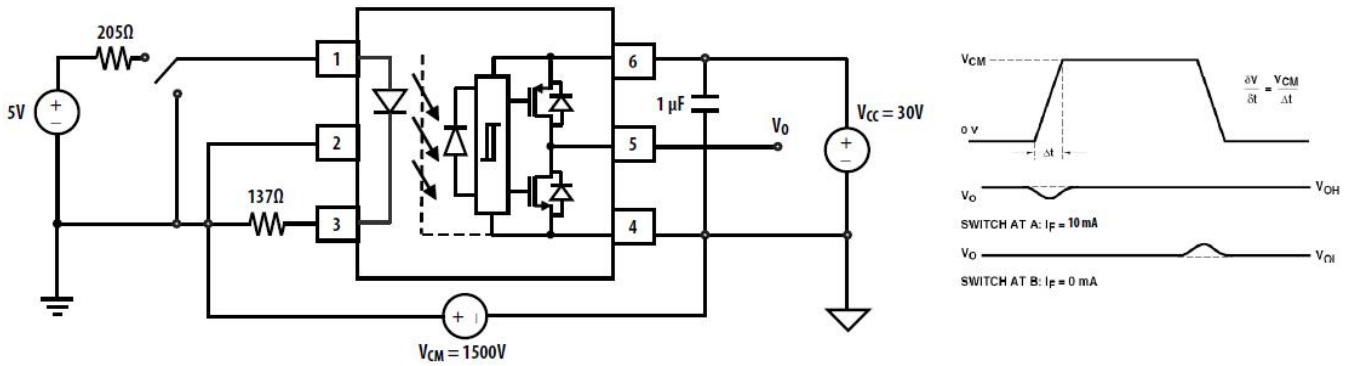

图例 21-共模抑制比测试电路及波形图
 Fig.21 CMR Test Circuit with Split Resistors Network and Waveforms

印字信息 Marking Information

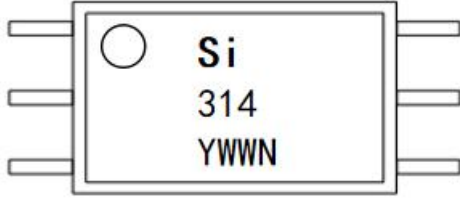

- ◆ Si: 生产商代码 Manufacturer's Code Marking
- ◆ 314: 器件型号代码 Device Part Number
- ◆ Y: 年份代码 Last Digit of Year (ex: 4=2024,5=2025)
- ◆ WW: 周号代码 Week Code (01 to 53)
- ◆ N: 特殊代码或无 Special code or None

命名规则 Naming Rule

Si-314-WY-ZTT

- ◆ Si: 生产商代码 Manufacturer's Code Marking
- ◆ 314: 器件型号代码 Device Part Number
- ◆ W: 框架材质 (C=铜)
- ◆ Y: G/None (G=环保, None=非环保)
- ◆ Z: 封装 (Z=P:LSOP-P, Z=W:LSOP-W)
- ◆ TT: 补充码 A~Z or 0~9 or None

封装外形尺寸 Package Outline Dimensions

Si-314P

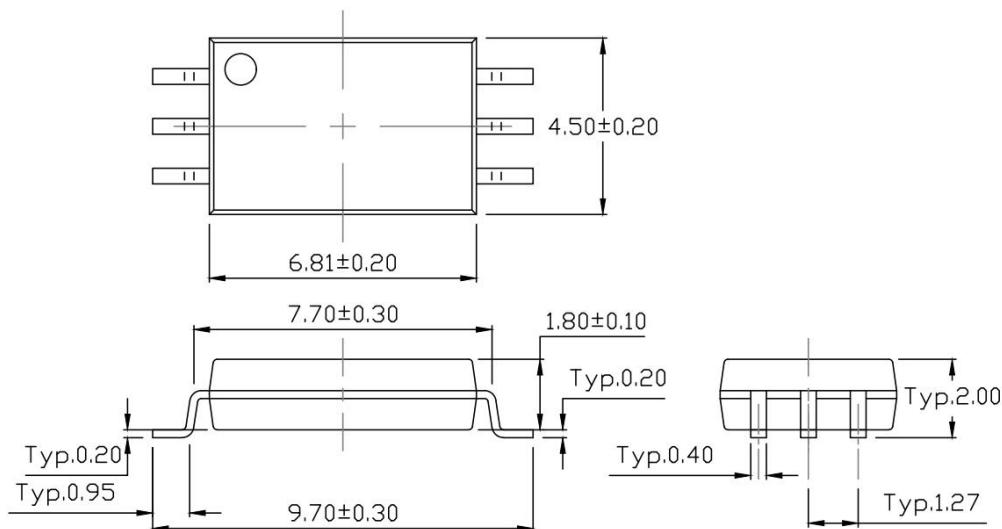

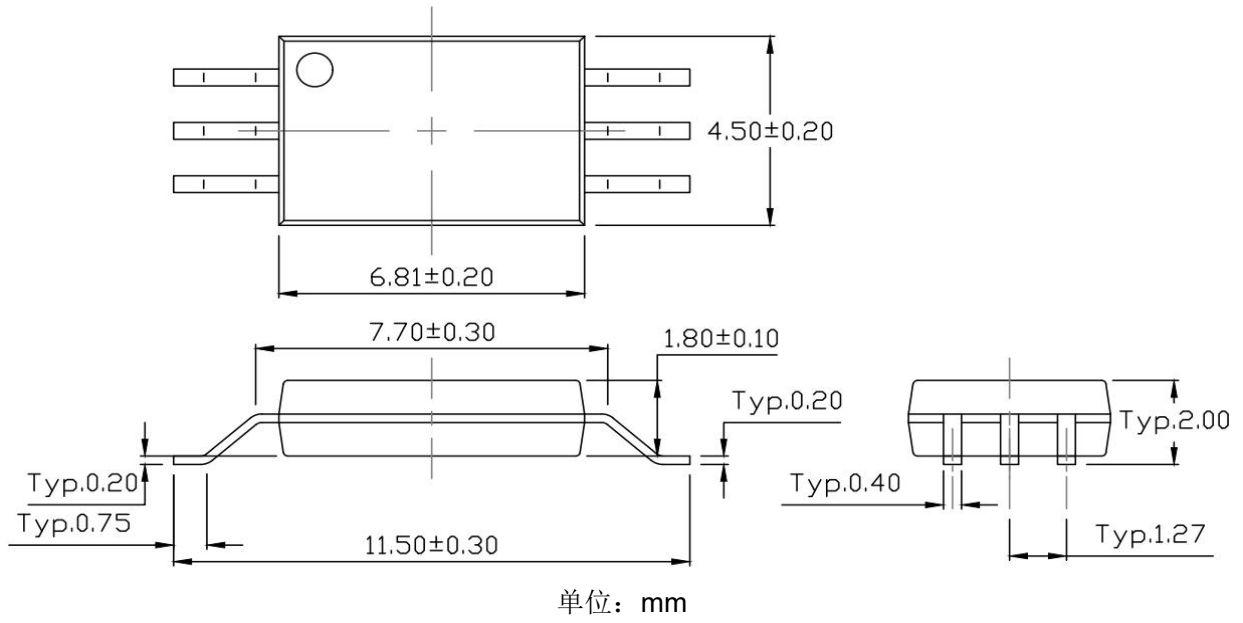

推荐焊盘尺寸 Recommended Footprint Patterns

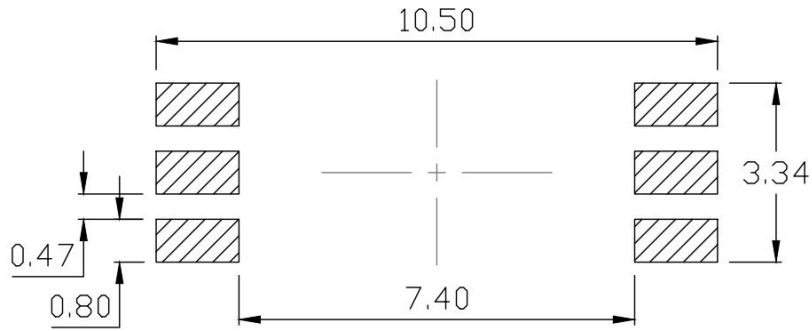

Si-314P

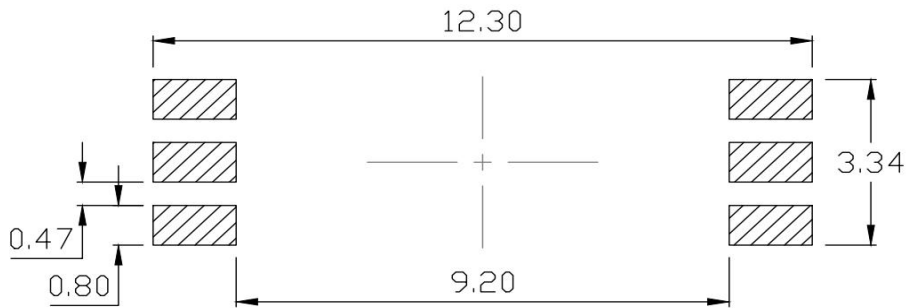

Si-314W

包装 Packing

封装类型 Package Type	每盘数量 Quantity per Reel	内盒数量 Quantity per Inner Box	外箱数量 Quantity per Carton	内盒尺寸 Inner Box Dimensions	外箱尺寸 Carton Dimensions
Stretched SO-6 P Type	3000 pcs/reel	9000 pcs/inner box	45,000 pcs/carton	360*360*69mm	450*380*380mm
Stretched SO-6 W Type	3000 pcs/reel	6000 pcs/inner box	30,000 pcs/carton	360*360*69mm	450*380*380mm

载带与卷盘 Tape and Reel

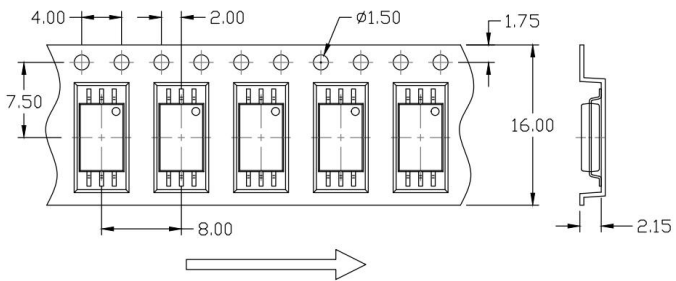
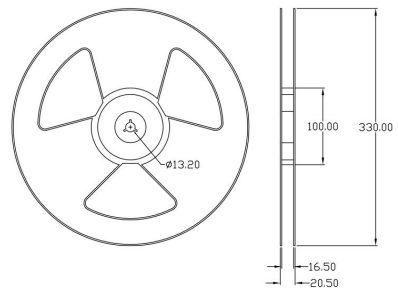
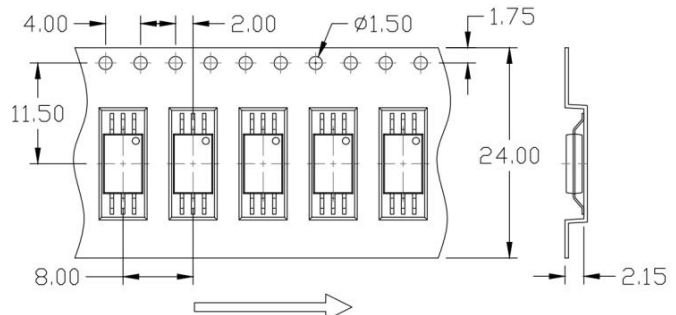
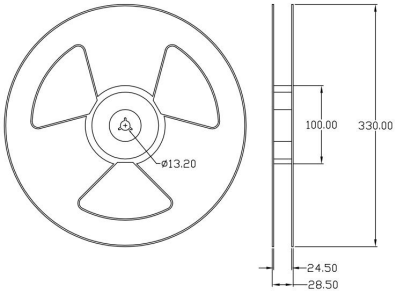
封装类型 Package Type	载带尺寸 Tape Dimensions	卷盘尺寸 Dimensions of Tape Reel
Stretched SO-6 P Type		
Stretched SO-6 W Type		

回流焊温度曲线 Solder Reflow Temperature Profile

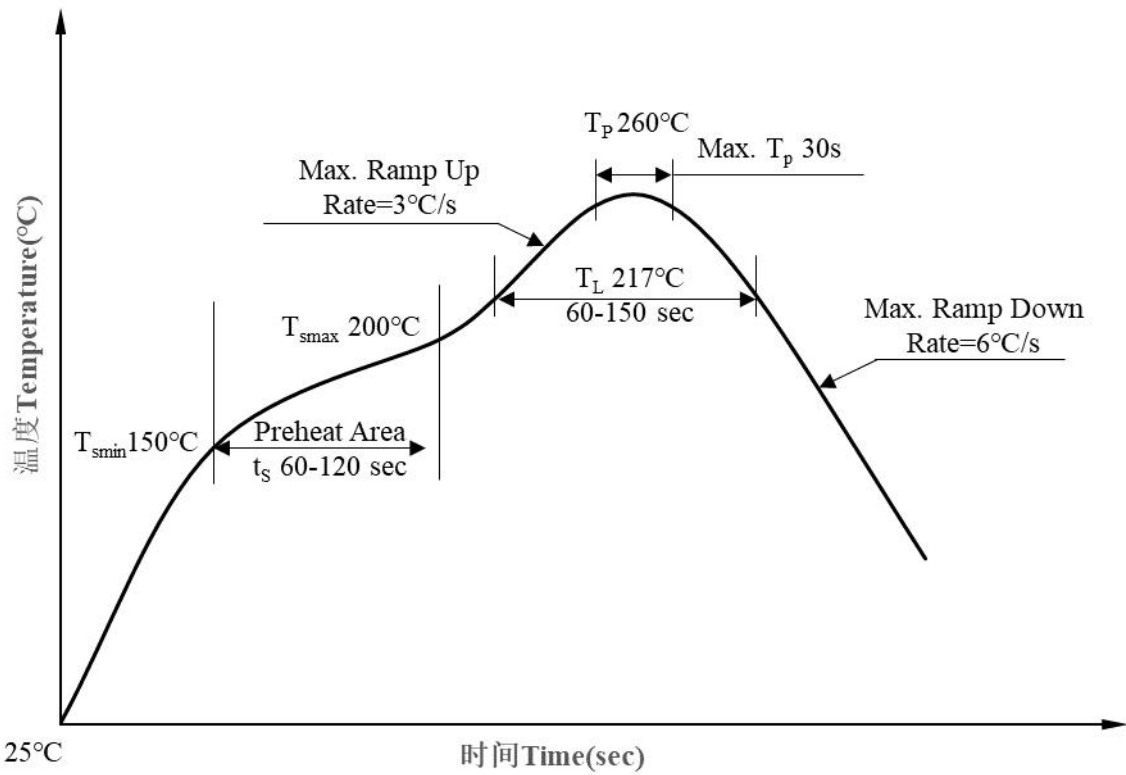

曲线项目 Profile Item		符号 Symbol	数值 Value	单位 Unit
预热区 Preheat Area	最低温度 Temperature Min.	T _{smin}	150	°C
	最高温度 Temperature Max.	T _{smax}	200	°C
	时间 Time (min. to max.)	t _s	60~120	sec
焊接区 Soldering Area	温度 Temperature	T _L	217	°C
	时间 Time	t _L	60~150	sec
峰值温度 Peak Temperature		T _p	260	°C
峰值温度 T _p 至 T _p -5°C 之间的时间 Time within 5 °C of Peak Temperature: T _p - 5°C		t _p	30	sec max.
上升速率 Ramp-up rate			3	°C / sec max.
下降速率 Ramp-down rate			6	°C / sec max.

注：参考 IPC/JEDEC J-STD-020D 标准。

Note: Reference: IPC/JEDEC J-STD-020D.

建议在所示的温度和时间条件下进行回流焊，最多不能超过三次。

One time soldering reflow is recommended within the condition of temperature and time profile shown below. Do not solder more than three times.

波峰焊温度曲线 Wave soldering Temperature Profile

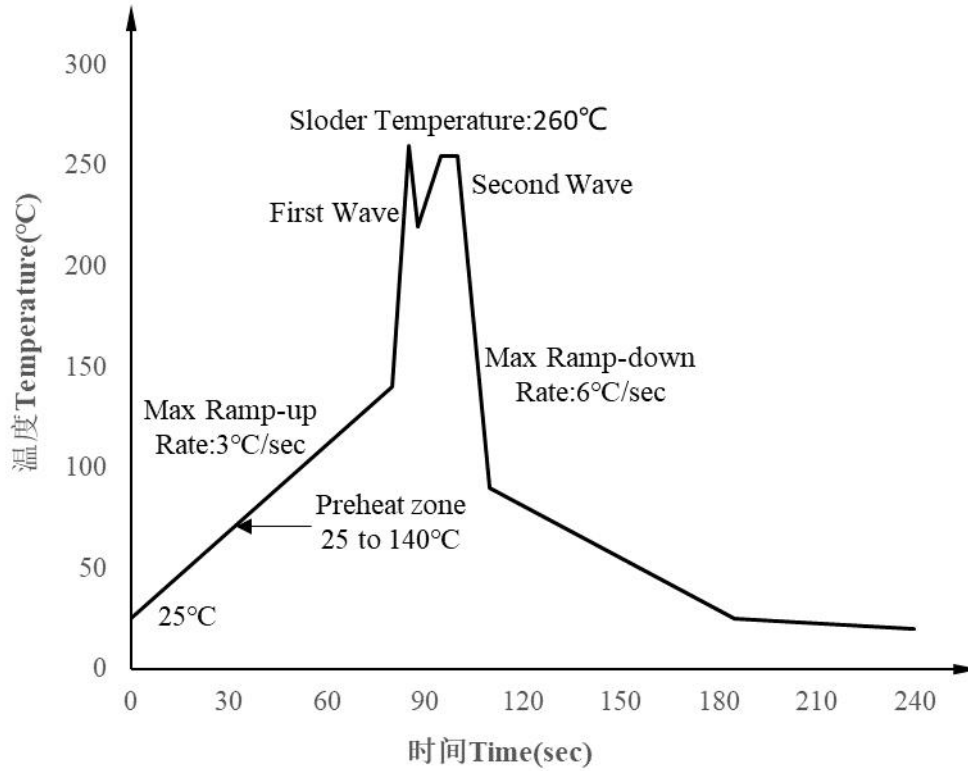

详情请参考 JEDEC 标准 JESD22-A111

For more details, please refer to the JESD22-A111 of JEDEC standards.

手工烙铁焊接 Hand soldering by soldering iron

- (1) 建议一次完成焊接。
One time soldering is recommended.
- (2) 温度 $360^{\circ}\text{C} \pm 5^{\circ}\text{C}$, 时间 $\leq 3\text{s}$ 。
Temperature: $360^{\circ}\text{C} \pm 5^{\circ}\text{C}$, within 3s.

声明 Disclaimer

1. 为提高产品可靠性、功能或设计或其他方面，硅耐所有产品规格可能会进行更改，恕不另行通知。
Silicon nice all product specifications are subject to change without notice to improve reliability, function or design or otherwise.
2. 使用本产品时请遵守规格书中的说明，硅耐对使用不符合这些规格表中说明的产品造成的损坏不承担任何责任。
When using this product, please observe the instructions in this specifications. Silicon nice assumes no responsibility for any damage resulting from use of the product which does not comply with the instructions included in this specification sheets.
3. 本规格书所展示的产品为电子应用中的一般用途而设计，如办公自动化设备、通信设备、音频/视频设备、电气应用和仪器仪表等。
The products shown in this specifications are designed for the general use in electronic applications such as office automation equipment, communications devices, audio/visual equipment, electrical application and instrumentation,etc.
4. 对于需要高可靠性或安全性的设备/装置，如太空应用、核电控制设备、医疗设备、任何“特定”应用等，请联系我们的销售代表。
For equipment/devices where high reliability or safety is required, such as space applications, nuclear power control equipment, medical equipment, any "specific" application,etc, please contact our sales representatives.
5. 如对文件中表述的内容有疑问，欢迎联系我们。
If you have any questions about the contents of the document, please contact us.